

NOTES:

1. NEMA 1 CONSTRUCTION.
2. BUS BARS SILVER PLATED COPPER - 98% CONDUCTIVITY.
3. BOX SHALL HAVE NAME PLATE WITH MANUFACTURER'S NAME.
4. FRONT DOORS SHALL BE SEALABLE & LOCKABLE.
5. ALL NUTS, BOLTS, FLAT WASHERS AND BELLEVILLE WASHERS SHALL BE NON MAGNETIC STAINLESS STEEL PER PSEG SPEC.
6. PHASES HAVE 1/4"-20 TAPPED HOLE BELOW AND ABOVE CT SHELF FOR NEUTRAL LUG.
7. LINE (TOP SIDE) & LOAD (BOTTOM SIDE) CLEARLY MARKED.
8. EXIT AND ENTRY PERMITTED THROUGH TOP, BOTTOM, SIDE AND REAR OF CABINET WITH PROPER REFERENCE OF NEC WIRE BENDING SPACE REQUIREMENTS.
9. NEUTRAL BONDING KIT AVAILABLE UPON REQUEST.

10.75 MIN  
BETWEEN PHASES

6.00  
MIN

6.00  
MIN

6.00  
MIN

PART #	AMPS	BUS WIDTH (IN)	BUS LEAVES	SETS - LINE & LOAD (500MCM)
NAV-NJ-CT-25	2500	5	2	6
NAV-NJ-CT-30	3000	4	3	8
NAV-NJ-CT-40	4000	4	4	10

B



TOP VIEW

PADLOCKABLE FRENCH DOOR WITH 3 PT CATCH

NON LIFTING HINGES FACTORY INSTALLED

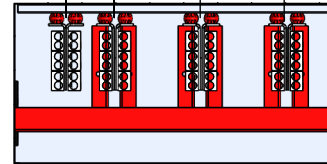

TOP VIEW SECTIONED

40.00

GLASTIC CT WIRING SUPPORT

PT FUSE HOLDER

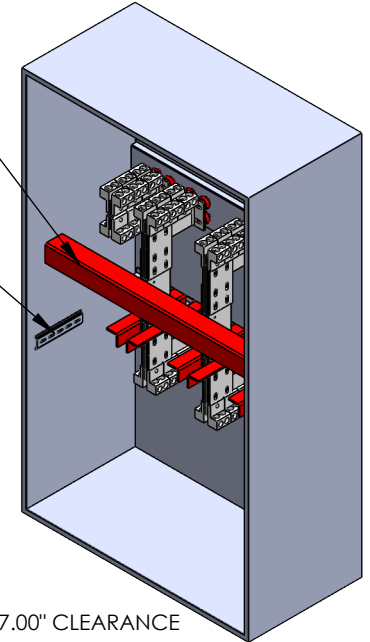

7.00" CLEARANCE FOR REMOVABLE LEAVES

GLASTIC CT MOUNT

A

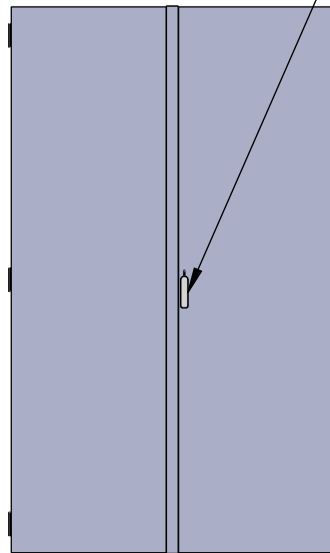

FRONT VIEW CLOSED

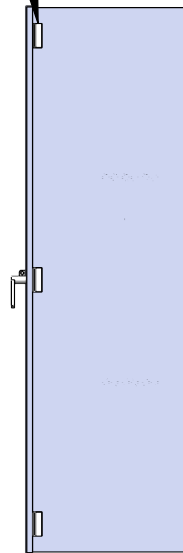

SIDE VIEW

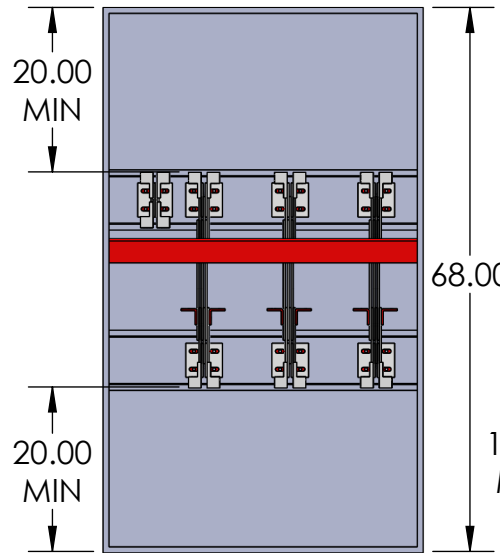

20.00  
MIN

20.00  
MIN

68.00

11.00  
MIN

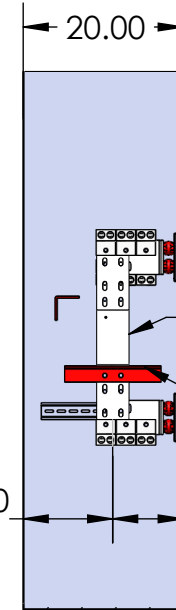

20.00

8.00  
MIN

FRONT VIEW OPENED

SIDE SECTIONED VIEW

B

A

DRAWN BY	NAME	DATE
REVIEWED BY	N. BOSETTI	9/10/2025



155 MARCUS BLVD  
HAUPPAUGE, NEW YORK 11788  
PH: (718) 257-2111 FAX: (718) 257-2626

MAT'L:	12 GAUGE GALV STEEL
FINISH:	GRAY POWDER COAT ANSI 61
WEIGHT:	

ALL DIMENSIONS ARE NOMINAL UNLESS EXPLICITLY STATED OTHERWISE

DRAWING TITLE:  
PSEG NJ 2500A-4000A CT CABINET OVERALL SPEC

PART #:  
NAV-NJ-CT-XX

**DO NOT SCALE DRAWING**

DESCRIPTION:  
NEMA 1 377 CT CABINET  
2500A-4000A 600V MAX  
PSEG NJ APPROVED  
WINDOW CT CABINET

SCALE:	1:24	SIZE	A	SHEET	1 OF 1	REV.	2
--------	------	------	---	-------	--------	------	---